

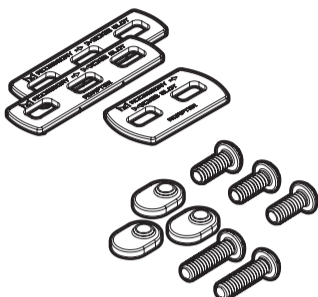

M-LOK™ TO MOE® ADAPTER



- ⚠ WARNING:** BEFORE STARTING, MAKE SURE THE WEAPON IS UNLOADED, THE CHAMBER IS EMPTY, AND THE SAFETY ENGAGED.
- ⚠ CAUTION:** PLEASE READ ALL INSTRUCTIONS BEFORE PROCEEDING. COMPONENTS UNDER SPRING PRESSURE MAY EJECT FORCEFULLY AND COULD CAUSE INJURY.
- ⚠ WARNING:** OBSERVE SAFE FIREARM HANDLING PRACTICES AT ALL TIMES. FAILURE TO DO SO MAY RESULT IN SERIOUS BODILY INJURY OR DEATH. MAGPUL INDUSTRIES SHALL NOT BE RESPONSIBLE FOR INJURY, DEATH OR PROPERTY DAMAGE RESULTING FROM FAULTY INSTALLATION, MISUSE, ILLEGAL USE, OR MODIFICATION OF THIS PRODUCT.

INSTALLATION INSTRUCTIONS

STEP 1: Fit the M-LOK to MOE Adapter to the Desired Accessory

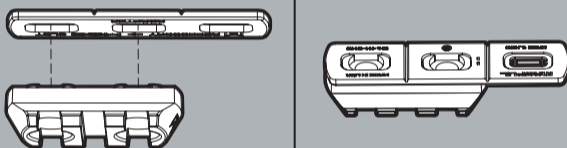

Ensuring that the hardware is removed, locate the appropriate *M-LOK to MOE Adapter* to the recoil lugs on the *M-LOK* accessory.

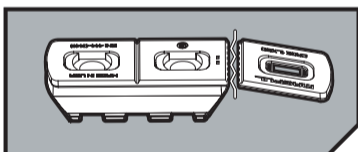

NOTE: The *M-LOK to MOE Adapter* plates are customizable to length by snapping sections off at the pre-determined lengths.

STEP 2: Position Accessory on Hand Guard

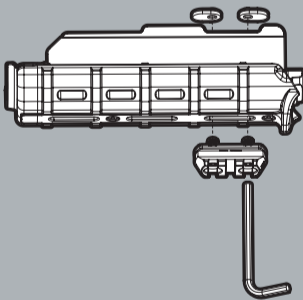

Install the *10-24 Button Head Screws* in the *M-LOK* accessory. Align with desired vent slot and insert. Thread the *Weld Nuts* onto the *10-24 Button Head Screws* and hand tighten using a *1/8"* hex key.

- ⚠ WARNING:** Take care to not over tighten screws. Over tightening may result in damage to the accessory or the hand guard.

STEP 3: Verify Installation

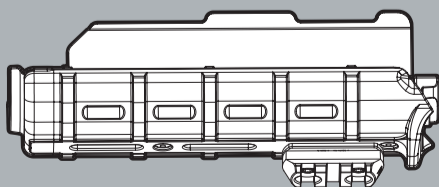

Perform final inspection including function check per **US Army TM 9-1005-23&P Unit and Direct Support Maintenance Manual (3-97)** to verify proper weapon function.

Always test fire your weapon before using it in an operational environment.